

# Proprioceptive feedback in running?

H. Geyer\*<sup>o</sup>, A. Seyfarth\*<sup>o</sup>, R. Blickhan\*

\* Institute of Sport Science, Friedrich Schiller-University, Seidelstr.20, D-07749 Jena

<sup>o</sup> MIT Leg Laboratory, 545 Technology Square, Cambridge MA 02139

## Introduction

Most studies addressing local feedback mechanisms are focused on posture and walking but only little is known about their role in fast locomotion. Some experimental studies on humans indicate a decrease in the activity of sensory signals with increasing speed (Collins et al. 1998, Simonsen and Dyhre-Poulsen 1999). It seems to be generally accepted that in fast movements the dynamics of the musculo-skeletal system dominate the system behavior. However, there is no explanation for the uniform spring-like leg operation used by many animals at different running gaits. In this study we address to what extend single muscle reflex loops can facilitate fast locomotion. Using a simple neuro-musculo-skeletal model we investigate the potential role of muscle reflexes in generating the spring-like leg behavior as observed in fast animal and human locomotion (Cavagna et al. 1964, 1977).

## Methods

A two-segment model with one Hill-type extensor muscle (Fig. 1) was used to investigate the leg operation in periodic contact tasks. The excitation-contraction coupling mechanism on the muscular level was described by a first order differential equation. This led to a muscle activation  $A(t)$  delayed by 30-40 ms with respect to the muscle stimulation  $STIM(t)$ .

The system was extended by a single loop feedback path taking muscular reflex mechanisms based on local proprioceptive information  $P(t)$  into account. Afferent muscle fiber length and velocity signals are provided by the muscle spindles. These signals are biased with an offset value representing the adjustment of the intrafusale fibres by  $\gamma$ -motoneurons. The Golgi tendon organ provide the muscle force  $F_m$  as an additional available proprioceptive signal to be feed back to the  $\alpha$ -motoneurons. The resulting muscle stimulation  $STIM(t)$  was given by the sum of the time delayed and gained sensory information  $\pm G \cdot P(t - \tau_p)$  and a ground signal  $STIM_0$ . The sign indicates positive or negative feedback with an excitatory or inhibitory postsynaptic potential (EPSP or IPSP, respectively) at the  $\alpha$ -motoneuron in the feedback pathway. In total six different single-loop feedbacks were investigated: positive or negative length, velocity and force feedback (PL, NL, PV, NV, PF, and NF). The stimulation level was limited to be between zero and the maximum muscle stimulation.

For each sensory information  $P(t)$  the feedback parameters (time delay  $\tau_p$ , ground signal  $STIM_0$ , and gain factor  $G$ ) were mapped to find an optimal adjustment for a periodic hopping pattern.

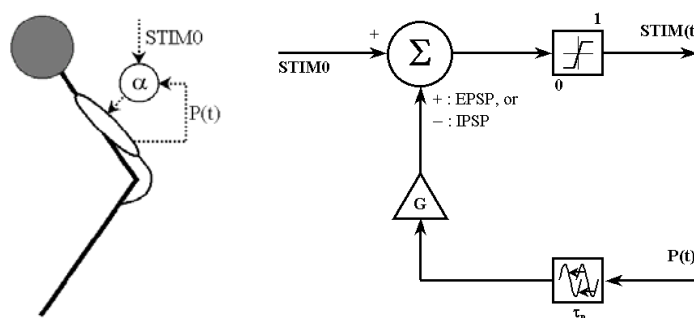

**Fig. 1** Two-segment model with one Hill-type extensor muscle including proprioceptive feedback.

## Results

Without reflexes periodic hopping could only be obtained by choosing an appropriate stimulation pattern. At a constant stimulation level STIM0 negative proprioceptive feedback led always to a continuous energy loss and consequently to a final resting leg position. Using the PL or PF feedback periodic hopping could be found. However, only the latter one (positive muscle force feedback) resulted in a quasielastic ground reaction force pattern (leg force  $F(t)$ ) similar to that observed experimentally (Fig. 2):

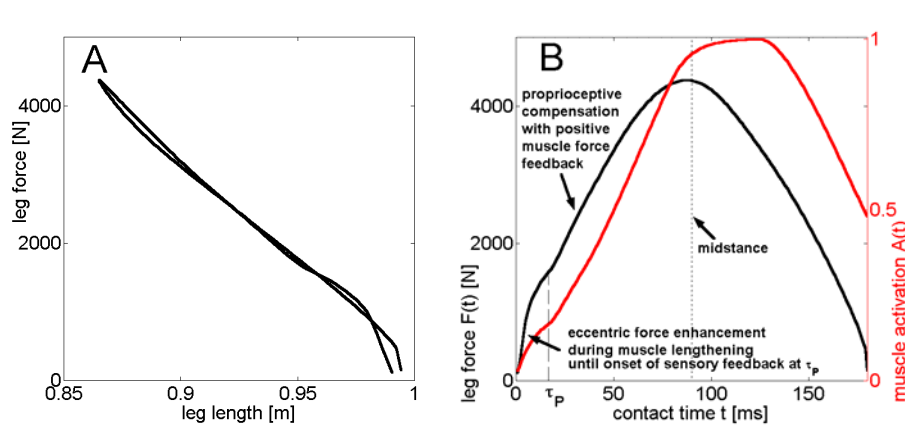

**Fig. 2** Positive muscle force feedback using Ib afferents of the Golgi tendon organ. Quasielastic linear leg operation was obtained without changing the central input during the contact phase.

Until the onset of proprioceptive feedback at time  $\tau_p$  the force pattern (Fig. 2B) was largely determined by the muscle's eccentric force enhancement (force-velocity curve). Without PF feedback this consequently led to an asymmetric pattern of the ground reaction force with respect to midstance (i.e. half ground contact). Feeding back the sensory information of the Golgi tendon organ (PF-feedback) resulted in a symmetrical pattern of the leg force. This behavior did neither depend on specific muscle properties (including force-length and force-velocity curves) nor on tendon compliance.

During the whole ground contact the muscle activation  $A(t)$  stayed submaximal. Consequently the time course of the muscle force was determined by the muscle reflex rather than by the mechanics of the musculo-skeletal system. The latter would have appeared if muscle activation has been saturated early in the stance phase.

## Discussion

We investigate the role of single loop muscle reflexes in fast locomotion with a simple neuro-musculo-skeletal model. In a first approach we concentrated on the generation of a spring-like leg behavior as observed in hopping and running. In the present study three different proprioceptive information (muscle fiber length, muscle fiber velocity or muscle force) were alternatively used for a single loop muscle feedback system.

Elastic properties of the leg could be found if proprioceptive feedback mechanisms were integrated. Although positive feedbacks are traditionally associated with a loss in system stability it turned out that this could be a powerful, robust and fast mechanism to facilitate elastic leg operation in a segmented musculo-skeletal system. Prochazka et al. (1997) showed that positive muscle force feedback is capable to stabilize the system in load bearing tasks. Here the force-length curve provides an instantaneous feedback gain servo neglecting the reflex signal in shortened muscle positions. The interaction between the externally applied load and the 'auto'-gained muscle force determines an equilibrium point at which the system is stabilized. In periodic bouncing tasks this equilibrium point is shifted into the flight phase

and therefore the trajectory of the point mass at the hip stabilizes on a certain jumping height. Until now there is only experimental evidence for positive muscle force feedback during walking (indirect evidences in posture, review: Zehr and Stein 1999). As there are differences in the published reflex time delays (Gossard et al. 1994, Guertin et al. 1994, Pearson and Collins 1993, Pratt 1995) there is an ongoing debate concerning long loop and muscle reflexes.

The predicted spring-like leg operation based on the muscle-reflex dynamics leads to general implications on the role of sensory feedback in motor control. A task dependent selection of distinct muscle reflexes and even a task dependent variation of feedback parameters may allow an adaptive leg behavior fulfilling different movement patterns based on the same morphological structure. This might be a key to the understanding of the flexibility of legged locomotor systems. The spring-like leg behavior as attained here is a generally observed feature in biological limbs and leads to several mechanical advantages in fast locomotion. One of these important mechanisms is the self stabilization during periodic forward bouncing (movement criterion for running and forward hopping; Seyfarth et al., submitted) which could be successfully demonstrated with the model described here (Fig. 3).

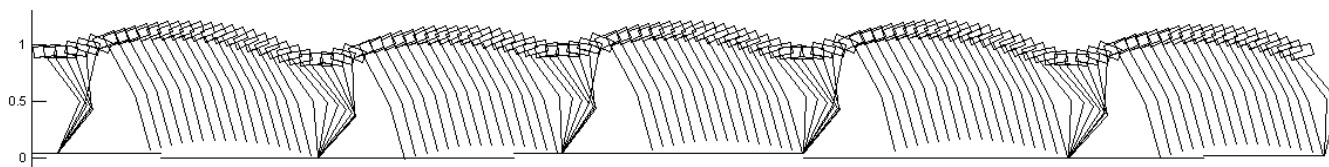

**Fig. 3** Dynamically stable running. The leg elasticity obtained using the neuro-muscular model allowed running patterns which are robust with respect to environmental changes (e.g. rough ground) and muscular properties. The necessary leg adjustment (movement criterion for running) was already predicted using a spring-mass model elsewhere (Seyfarth et al.).

In future we are aiming to address the intersegmental muscular coordination during fast locomotion. Furthermore, we will try to identify appropriate reflex structures for other types of movement like vertical jumping (drop jump, squat jump, etc.).

## References

- Cavagna, G. A., Saibene, F. P., and Margaria, R., *J. of Appl. Physiol.* 19(2), 249-256, 1964.  
Cavagna, G. A., Heglund, N. C., and Taylor, C. R., *American J. of Physiol.* 233(5), 243-261, 1977.  
Collins, D. F., Cameron, T., Gillard, D. M., and Prochazka, J. *Physiol.* 508 (2), 635-643, 1998.  
Gossard, J. P., Brownstone, R. M., Barajon, I., Hultborn, H., *Exp. Brain. Res.* 98, 213-228, 1994.  
Guertin, P., Angel, M.J., Jiminez, I., and McCrea, D. A., *Soc. Neurosci. Abstr.* 20, 1582, 1994.  
Pearson, K. G. and Collins, D. F., *J. Neurophysiol.* 70, 1009-1017, 1993.  
Pratt, C. A., *J. Neurophysiol.* 73, 2578-2583, 1995.  
Prochazka, A., D. Gillard, and Bennett, D. J., *J. Neurophys.* 77, 3237-3251, 1997.  
Seyfarth, A., Geyer, H., Günther, M., and Blickhan, R., *J. Biomech.*, submitted.  
Simonsen, E. B. and Dyhre-Poulsen, P., *J. Physiol.* 515(3), 929-39, 1999.  
Zehr, E. P. and Stein, R. B., *Prog. in Neurobiol.* 58, 185-205, 1999.